

Timing Mode: **DELAY ON BREAK**
 Category: **TIMER WITH RELAY**
 Series: **TGM**

CUBE RELAY, 10-30 AMPS

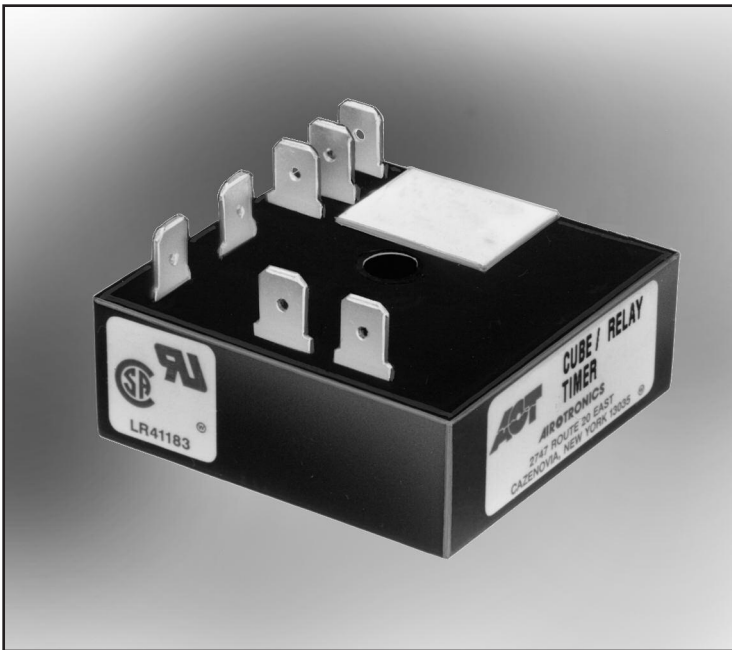

TGM Timers

TGM series Cube Relay Delay on Break timers are a unique combination of digital CMOS timing circuitry with a relay output in a compact 2" x 2" configuration.

These units provide the same functional performance as plug-in relay timers, but at significant cost savings.

Key features: Normally Open (N.O.) isolated initiate switch; relay common is totally isolated.

Timing Mode

Input voltage is applied continuously. Upon closure of the normally open isolated external initiate switch, the load is energized, and remains energized as long as it is closed. When the external initiate switch opens, the time delay is started. At the end of the time delay, the load is de-energized, and the timer is ready for another cycle.

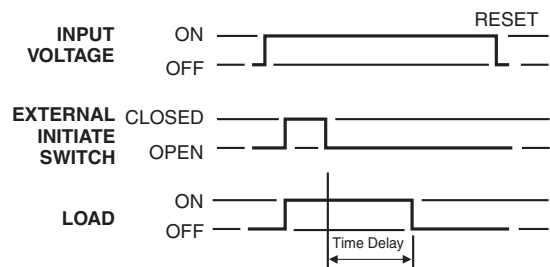

FEATURES

- High current-carrying capacity up to 30 amps
- Transient protected
- 100% Load isolation
- No leakage in N.O. position
- No heat sinking required
- Available in any time delay period required
- Digital CMOS timing
- No minimum load required
- Totally encapsulated for protection from harsh environments
- 100% Operational testing before shipping
- 
- RoHS compliance available

BASIC WIRING AND DIMENSIONS

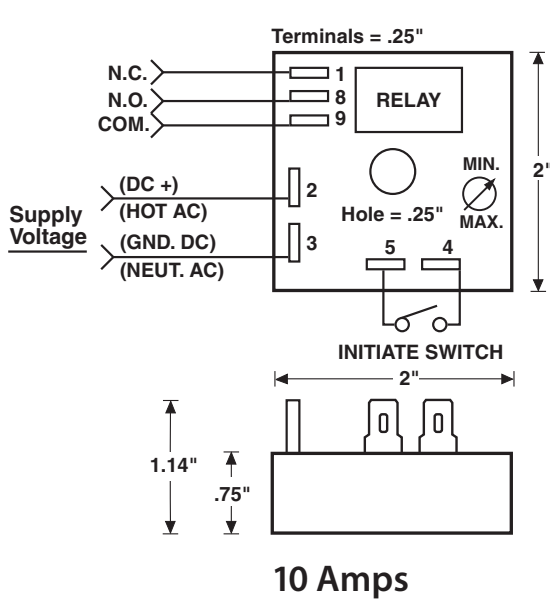

See page 177 for DPDT and 30 Amp Diagrams

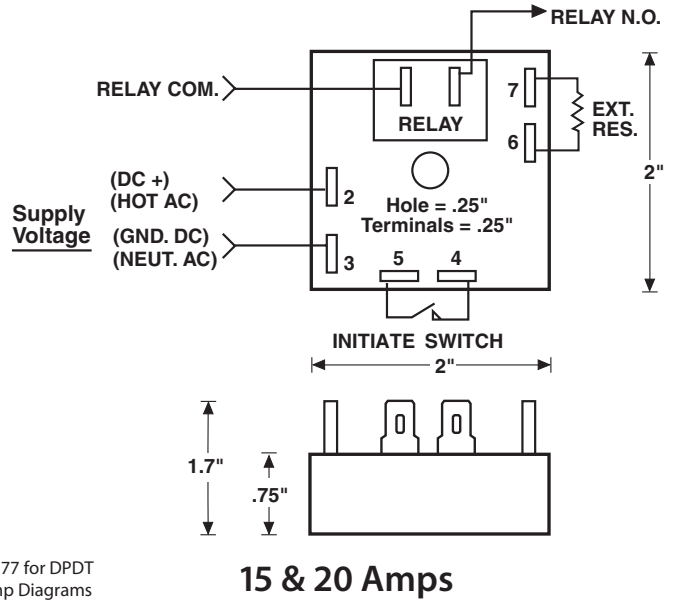

SPECIFICATIONS

Input Voltage:

VDC: 12, 24 or 48
 VAC: 24, 48, 120 or 230, 50/60Hz

Time Delay:

Timing Mode: Delay on Break
Type: Digital CMOS
Time Range: 0.1 seconds to 24 hours
Time Adjustments: Factory-fixed time period; variable, with adjustments on timer, or terminals for external resistor or potentiometer

Repeatability: ± 0.5%

Setting Accuracy: Fixed time period: ±10% of nominal time.

Variable time range:
 +15% -5% max. time, -10% min. time

Reset/Recycle Time: 25 milliseconds

Initiate Time: 6 milliseconds or less

Relay Life Expectancy:

Mechanical: 20 million operations
Electrical: 100,000 operations

Protection:

Polarity Protection: All DC units have reverse polarity protection
Transient Protection: 18 joules
Dielectric Strength: 1800V RMS 60Hz

Temperature Ranges:

Storage: -40°C to +85°C
Operating: -25°C to +65°C

Physical Data:

Mounting: Surface with one #8 screw
Connection & Termination: 0.25" quick connects

OPTIONS SELECTION

Mode of Operation	Series	Input Voltage	Examples of Time Ranges	Time Adjustment Method	Relay Output Form	Options
Delay On Break	TGM	1 120 VAC	VARIABLE TIME PERIODS 0001 0.1 to 1 sec. 0010 .2 to 10 sec. 0100 2 to 100 sec. 1000 20 to 1000 sec. Any range up to 24 hours available.	A Variable, integral, knob on timer. B Variable, external knob remote. C Fixed, internal, factory set. D Fixed, external, resistor remote.	1 SPDT	H 10 Amps JN 15 Amps (1.0 HP) J 20 Amps (1.5 HP) Z 30 Amps W Wires S Special
		2 230 VAC			2 SPST (N.O.)	
		3 24 VAC	FIXED TIME PERIODS Specify time in full seconds or hours followed by the letter "S" or "H" and the decimal amount of the main time unit. Examples: 5S5 is 5.5 secs 5H5 is 5.5 hours		3 SPST (N.C.)	
		4 24-28 VDC			*4 DPDT	
		5 48 VAC				
		6 48 VDC				
		7 12 VDC				
		8 Any in between AC voltage (specify)				
		9 Any in between DC voltage (specify)				

Specifications subject to change without notice.